IrDA SIR Integrated Transceiver

Description

The TFDS 3000 is an infrared transceiver for data communication systems. The transceiver is compatible to the IrDA standard which allows data rates up to 115 kBaud.

An internal AGC (Automatic Gain Control) ensures proper operation under EMI conditions.

Features

- Compatible to IrDA standard
- SMD side view
- Low profile (height = 5.6 mm max.)
- Microcomputer compatible
- No external components
- Low power consumption
- Wide supply voltage range (3 to 5.5 V)
- AGC for EMI immunity
- Shut-down pin for power management

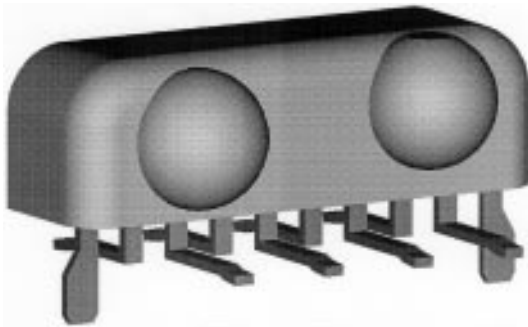

Pin description:

- 1: IRED Cathode
- 2: Rxd (Output)
- 3: V_{CC} (Supply Voltage)
- 4: Ground
- 5: NC *)
- 6: SD (Shut-down)
- 7: Txd (Input)
- 8: IRED Anode

*) optional sensitivity control for OEMs only

Absolute Maximum Ratings

Reference point Pin 4, unless otherwise specified

Parameter	Test Conditions	Symbol	Value	Unit
Supply Voltage Range		V_{CC}	-0.5 to 6	V
Input Currents	All pins		10	mA
Output Sinking Current			25	mA
Power Dissipation	See figure 1	P_{tot}	200	mW
Junction Temperature		T_j	125	°C
Ambient Temperature Range (Operating)		T_{amb}	0 to 70	°C
Storage Temperature Range		T_{stg}	-25 to +85	°C
Soldering Temperature	t = 20 s @ 215°C		230 (typ. 215)	°C
Average IRED Current		$I_{IRED(DC)}$	100	mA
Repetitive Pulsed IRED Current	< 90 μ s, t_{on} < 20%	$I_{IRED(RP)}$	500	mA
Peak IRED Current	< 2 μ s, t_{on} < 10%	$I_{IRED(PK)}$	1	A
IRED Anode Voltage		$V_{IRED(A)}$	-0.5 to $V_{CC} + 0.5$	V
Transmitter Data Input Voltage		V_{Txd}	-0.5 to $V_{CC} + 0.5$	V
Receiver Data Output Voltage		V_{Rxd}	-0.5 to $V_{CC} + 0.5$	V

Basic Characteristics

$T_{amb} = 25^\circ\text{C}$, $V_{CC} = 5\text{ V}$, unless otherwise specified

Parameter	Test Conditions	Symbol	Min.	Typ.	Max.	Unit
Transceiver						
Supported Data Rates			2.4		115.2	kBit/s
Supply Voltage Range reduced function down to 2.6 V		V_{CC}	3	5	5.5	V
Supply Current	SD = LOW or OPEN (RECEIVE mode)	I_S		1.3	2.5	mA
Supply Current	SD = HIGH (STANDBY mode)	I_S		0.4	0.5	mA
Receiver						
Min. Detection Threshold Irradiance **)	$\alpha = \pm 15^\circ$	E_{emin}		0.025	0.035	Wm^{-2}
Max. Detection Threshold Irradiance **)	$\alpha = \pm 90^\circ$	E_{emax}	3300	5000		Wm^{-2}
Logic Low Receiver Input Irradiance		$E_{emaxlow}$			0.004	Wm^{-2}
Max. DC Irradiance	$\alpha = \pm 90^\circ$	E_{edcmax}	400			Wm^{-2}
Output Voltage Rxd	Active, C = 15 pF, R = 2.2 k Ω	V_{OL}		0.5	0.8	V
Output Voltage Rxd	Non-active, C = 15 pF, R = 2.2 k Ω	V_{OH}	$V_{CC} - 0.5$			V
Output Current	$V_{OL} < 0.5\text{ V}$ C = 15 pF, R = 2.2 k Ω			4		mA

**) BER = 10^{-9} is target of IrDA specification, defined sensitivities not related to BER = 10^{-9}

Parameter	Test Conditions	Symbol	Min.	Typ.	Max.	Unit
Rise and Fall Time	C = 15 pF, R = 2.2 kΩ	t _r	20		200	ns
Rxd Signal Electrical Output Pulse Width	2.4 kBd		1		20	μs
Rxd Signal Electrical Output Pulse Width	115.2 kBd		1		8	μs
Output Delay Time (Rxd) Max. delay of leading edge of output signal related to leading edge of optical input signal	Output level = 0.5 × V _{CC} @ E _c = 0.040 W/m ²			1	2	μs
Jitter, Leading Edge of Output Signal	Over a period of 10 bit, 115.2 kBd				2	μs
Output Delay Time (Rxd) Max. delay of trailing edge of output signal related to trailing edge of optical input signal	Output level = 0.5 × V _{CC}				6.5	μs
Latency	Recovery from last transmitted pulse to 1.1 × threshold sensitivity	t _L		100	800	μs
Transmitter						
Supply Voltage Switching Spec's only cover 4.5 to 5.5 V		V _{CC}	3		5.5	V
Driver Current IRED I _d can be adjusted by variation of R _S	Current limiting resistor in series to IRED: R _S = 10 Ω @ 5 V	I _d		0.3	0.5	A
Logic Low Transmitter Input Voltage		V _{IL} (Txd)	0		0.8	V
Logic High Transmitter Input Voltage	Max. input current I _{in} < 100 μA	V _{IH} (Txd)	2.4		V _{CC}	
Output Radiant Intensity α = ± 15°	Current limiting resistor in series to IRED: R _S = 10 Ω, V _{CC} = 5 V		40	60	200	mW/sr
Angle of Half Intensity		α		± 24		°
Peak Wavelength of Emission		λ _p	850		900	nm
Halfwidth of Emission Spectrum				60		nm
Optical Rise / Falltime	115.2 kHz square wave signal (1:1)			200	600	ns
Output Radiant Intensity	Logic LOW level				0.4	μW/sr
Overshoot, Optical					25	%
Rising Edge Peak-to-Peak Jitter	Over a period of 10 bits, independent on information content	t _j			0.2	μs

**) BER = 10⁻⁹ is target of IrDA specification, defined sensitivities not related to BER = 10⁻⁹

Board Hole Diagram

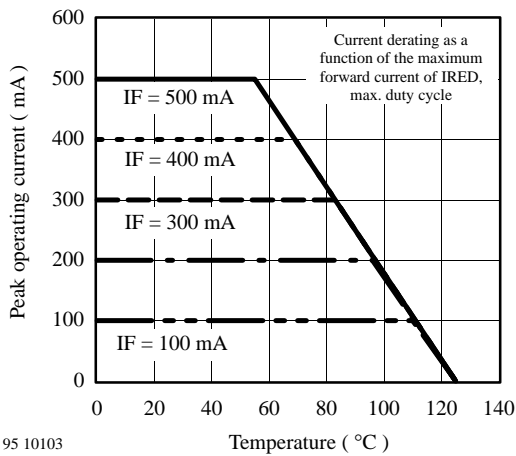
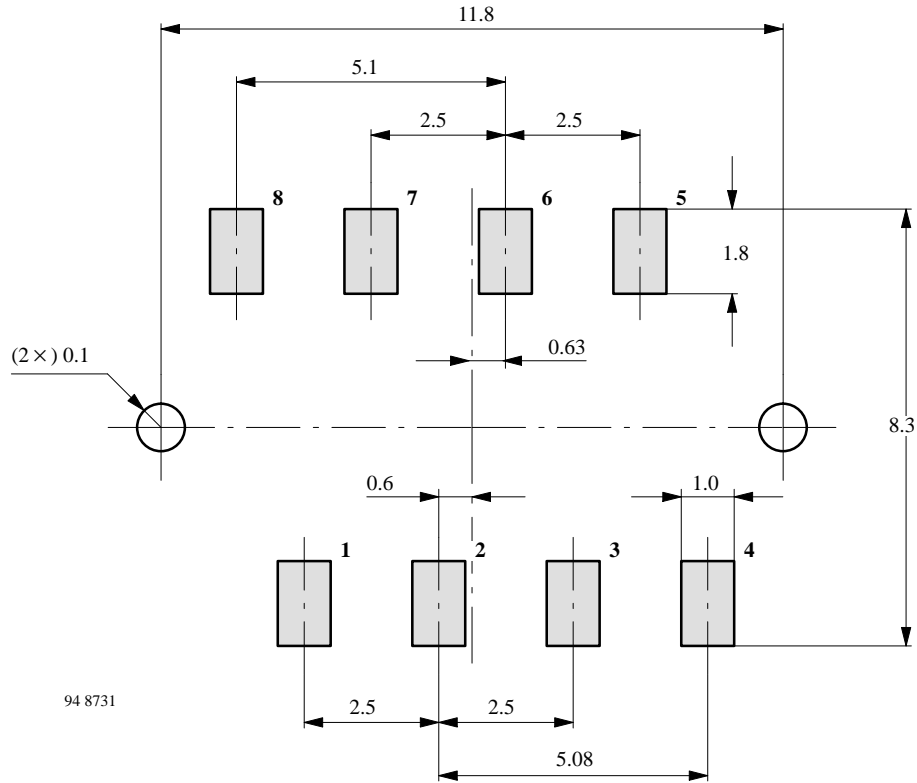
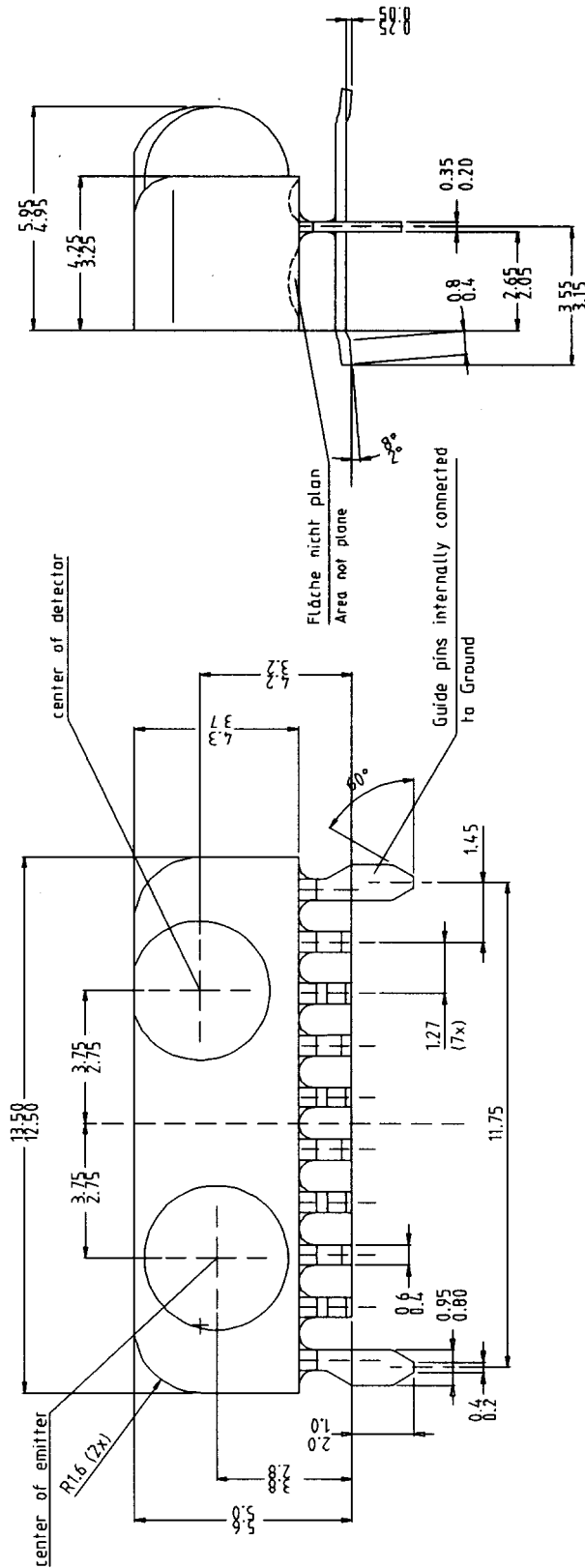

Figure 1. Current derating as a function of ambient temperature

Dimensions in mm



pin	function
8	LED Anode
7	TxD (Input)
6	SD (Shutdown)
5	n.c. x)
4	Ground
3	Vcc
2	RxD (Output)
1	LED Cathode

x) optional Sensitivity Control

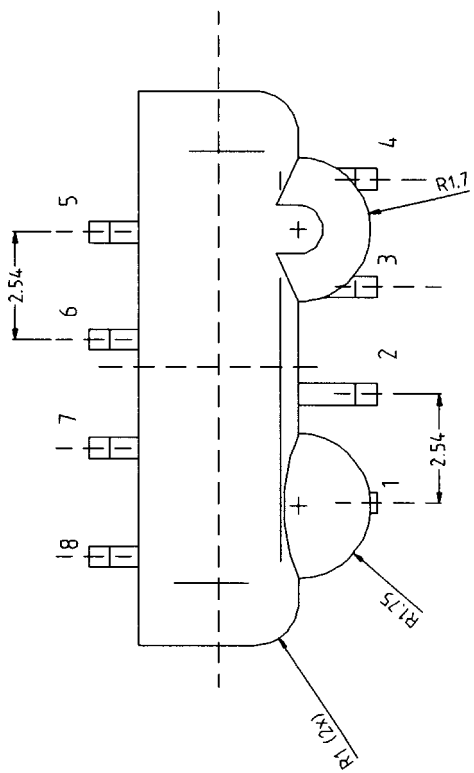

Ozone Depleting Substances Policy Statement

It is the policy of **TEMIC TELEFUNKEN microelectronic GmbH** to

1. Meet all present and future national and international statutory requirements.
2. Regularly and continuously improve the performance of our products, processes, distribution and operating systems with respect to their impact on the health and safety of our employees and the public, as well as their impact on the environment.

It is particular concern to control or eliminate releases of those substances into the atmosphere which are known as ozone depleting substances (ODSs).

The Montreal Protocol (1987) and its London Amendments (1990) intend to severely restrict the use of ODSs and forbid their use within the next ten years. Various national and international initiatives are pressing for an earlier ban on these substances.

TEMIC TELEFUNKEN microelectronic GmbH semiconductor division has been able to use its policy of continuous improvements to eliminate the use of ODSs listed in the following documents.

1. Annex A, B and list of transitional substances of the Montreal Protocol and the London Amendments respectively
2. Class I and II ozone depleting substances in the Clean Air Act Amendments of 1990 by the Environmental Protection Agency (EPA) in the USA
3. Council Decision 88/540/EEC and 91/690/EEC Annex A, B and C (transitional substances) respectively.

TEMIC can certify that our semiconductors are not manufactured with ozone depleting substances and do not contain such substances.

We reserve the right to make changes to improve technical design and may do so without further notice.

Parameters can vary in different applications. All operating parameters must be validated for each customer application by the customer. Should the buyer use TEMIC products for any unintended or unauthorized application, the buyer shall indemnify TEMIC against all claims, costs, damages, and expenses, arising out of, directly or indirectly, any claim of personal damage, injury or death associated with such unintended or unauthorized use.

TEMIC TELEFUNKEN microelectronic GmbH, P.O.B. 3535, D-74025 Heilbronn, Germany
Telephone: 49 (0)7131 67 2831, Fax number: 49 (0)7131 67 2423